

Offset Block Component

Dimensions / Weight

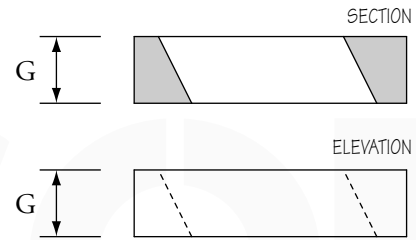
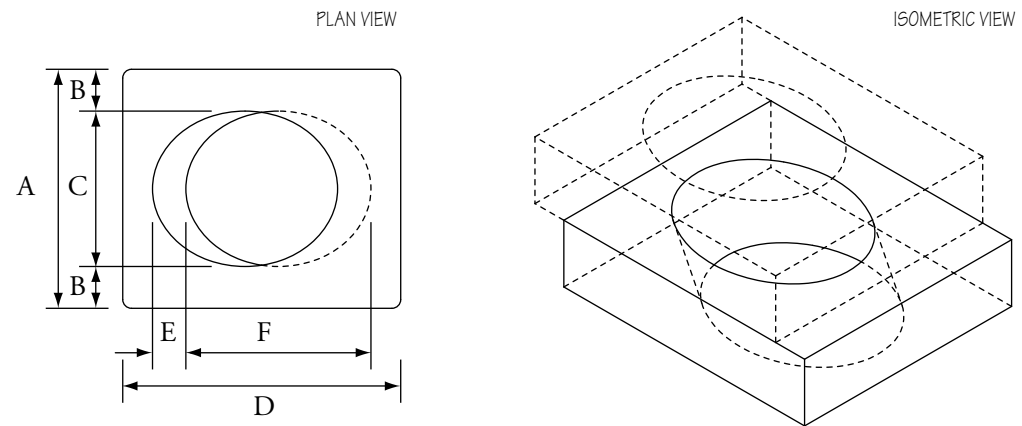

| | A | B | C | D | E | F | G |
|------------------|---------|--------|-----|---------|----|---------|----|
| 14" Offset Block | 21 1/2" | 3 3/4" | 14" | 24 7/8" | 3" | 16 1/8" | 6" |

| | weight* |
|------------------|----------|
| 14" Offset Block | 110 lbs. |

* weight based on raw pumice material only